

Retainer for DX 60/100 3-D "Glass"

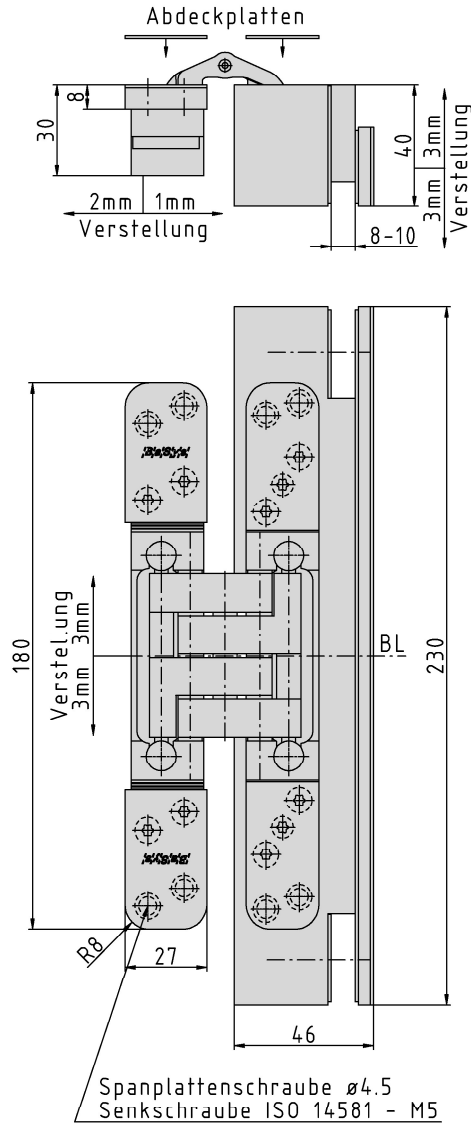

Section drawing

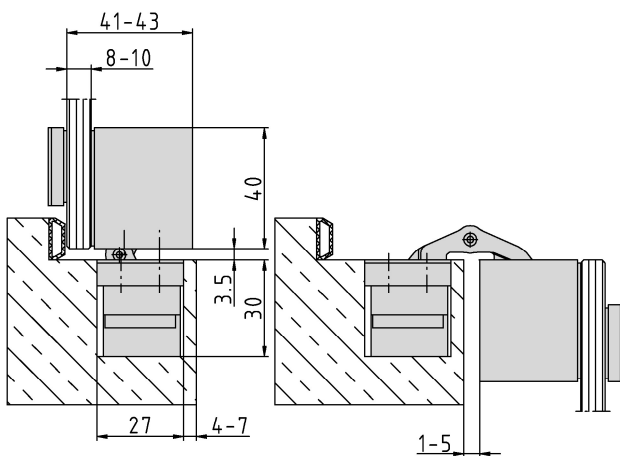

Additional Information

Standard load: Maximum door weight 100 kg (per pair)
 Application: Glass doors, retainer provides connection of the concealed hinge to the leaf
 Note: incl. fixing screws
 Combination: PIVOTA® DX 60 3-D,
 PIVOTA® DX 100 3-D,
 PIVOTA® DXS 100 3-D "Steel",
 PIVOTA® DXE 100 3-D "Enox"

item no.	Finish	PU
040856	without finish	1
040974	without finish	1